

CSM850

SEWAGE CUTTER PUMP

- Heavy duty construction
- 35 mm free passage
- Semi open cutter impeller
- Moisture sealed cable inlet
- Hmax to 15.5 m
- Qmax to 1050 LPM



DESCRIPTION

The CSM850 range of semi open cutter-style impeller submersible pumps are made from heavy duty cast iron and high grade stainless steel. They operate completely immersed in the liquid to be pumped which provides for the cooling of the motor from the outside. Built-in auto-cut protector. Designed for pumping sewage wastewater containing particles up to 35 mm in diameter and where stringy materials may be present.

PERFORMANCE

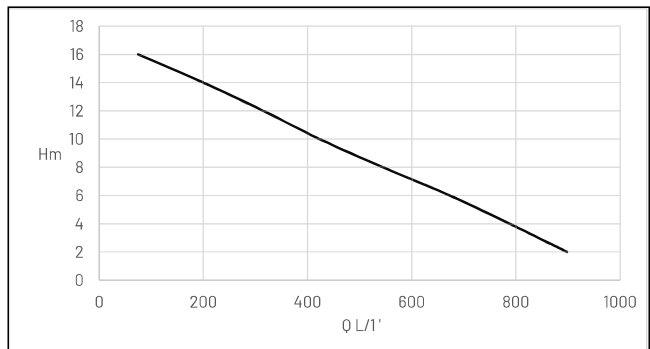

Type	Delivery head H [m]	4	6	8	10	12	14
CSM850CF / CS	Flow rate Q [m ³ /h]	55.8	46.8	38.4	30	20	9.0

We reserve the right to change specifications without notice.

This data is represented in the performance curve as a limit of application.

SCOPE OF SUPPLY

Pump ready for connection acc. to EN 12050 with 3" flange connection, 3" flanged elbow to 3" 2 bolt flange connection, 2 bolt flange connection to BSP FI and 80mm x 3" BSP MI hose connector, cable and plug.

MECHANICAL DATA

Pump	Vertical single-stage
Free passage	35 mm
Bearing	Self-lubricating ball bearings
Oil chamber	Yes
Mechanical seal	Double M.seals (lubricated in oil chamber)
Shaft	Stainless steel

Impeller	Cast iron
Motor housing	Stainless steel
Pump housing	Cast iron
Submersible	Yes
Pressure outlet	3"
Temperature max.	40°C

ELECTRICAL DATA

Power line	10m H07RN-F
Type of enclosure	IP 68

Insulation class	F
Rotation speed	2850

Type	Code No.	Voltage	Motor rating (kW) P2	Current (A)	Starting	Start cap.	Run cap.	Free passage (mm)	Weight
With level control									
CSM850CF	CSM850CF	1/N/PE~230 V	1.5	10	CS/CR	15µF	100µF	35	35 kg
Without level control									
CSM850CS	CSM850CS	1/N/PE~230 V	1.5	10	CS/CR	15µF	100µF	35	35 kg

PSC: Permanently Split Capacitor CS/CR: Capacitor Start/Capacitor Run (centrifugal switch) DOL: Direct On Line

Dimensions CSM850 (mm)

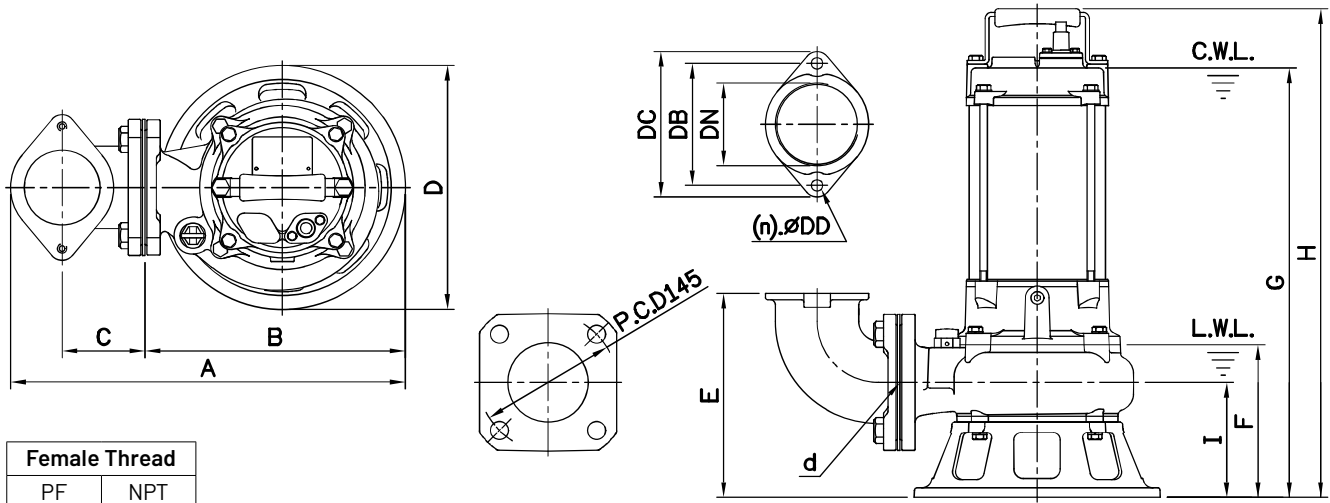

Female Thread	
PF	NPT

PUMP CONTROLLER

Type	Code no.	Single pump controller	Dual pump controller	Float switch 10 m	Float switch 15 m	Float switch 20m	Float switch 30 m	Float switch 40 m
With / without level control								
CSM850	CSM850CF / CS	PPC-15002-D	PPC-30010-D	FSW-10M	FSW-15M	FSW-20M	FSW-30M	FSW-40M