

543 SERIES

MOULDED JET FARMMASTER PUMP

Horizontal, single-stage, surface mounted centrifugal pump. Jet and venturi assisted performance with closed impeller for pumping debris free water. Noryl pump casing with 1¼" BSP (male) inlet and ¾" BSP (female) outlet.



APPLICATIONS

Domestic, industrial or rural pressure pump for use as a manual or an automatic pressure system.

Stock watering, irrigation and water transfer. Option of a large range of water sources including tanks, bores, dams, creeks and rivers.

PUMP CONSTRUCTION MATERIALS

Component	Material
Pump casing	Noryl
End shield	Cast iron
Baffle	Noryl
Priming / drain plug	Acetal
Impeller	Polycarb 20% glass-filled
Diffuser	Noryl
Shaft Sleeve	Nylon
Motor shaft	Mild steel
O-ring	Nitrile
Mechanical seal	Carbon / ceramic

KEY FEATURES

- Industrial grade corrosion resistant thermoplastic.
- No moving parts down bore.
- Built-in check valve.
- Shallow well lifts to 7.6m.
- Manual or automatic system.
- Inbuilt thermal overload
- Max. head - 41m
- Max. flow - 118 lpm

OPERATING CONDITIONS

Fluid:	Water
Max. Water temperature:	55°C
Min. Water temperature:	1°C
Max. Ambient temperature:	40°C
Min. Working pressure:	140kPa
Max. Working pressure:	600kPa

Suitable for pumping clean non-aggressive liquids without solids or fibres in suspension.

ELECTRICAL DATA

Type	Type of current	Voltage ± 10%	Frequency Hz	Motor rating kW		Nominal RPM	Current ampere	Locked rotor current	Motor protection	Insulation class	IP rating
				P1	P2						
543	1-phase	230	50	1.4	1.1	2900	6.4 A	42 A	Auto	B	44

PERFORMANCE

Type	Pressure switch setting (kPa)	Suction depth (m)	Total head in metres					Maximum pump pressure (kPa)
			15	21	27	34	40	
			Capacity (litres per minute)					
543	210-350	0	117	105	65	28		390
		3	94	84	52	22		360
		6	67	60	37	16		330
		7.6	47	42	26	11		315

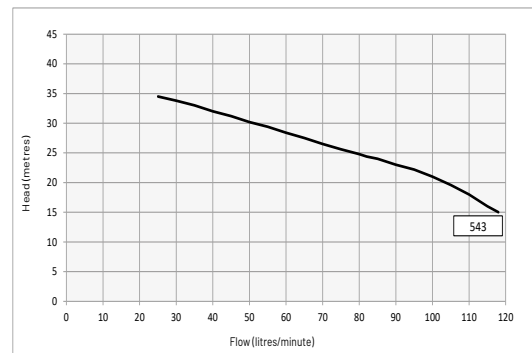

DIMENSIONS

Type	Maximum L x W x H	Weight approx.	Inlet	Pump outlet	Pressure kit outlet	Carton L x W x H	Packed weight
543	530 x 230 x 290 mm	25 kg	1/4" BSP (male)	3/4" BSP (female)	1" BSP (female)	590 x 300 x 330 mm	27 kg

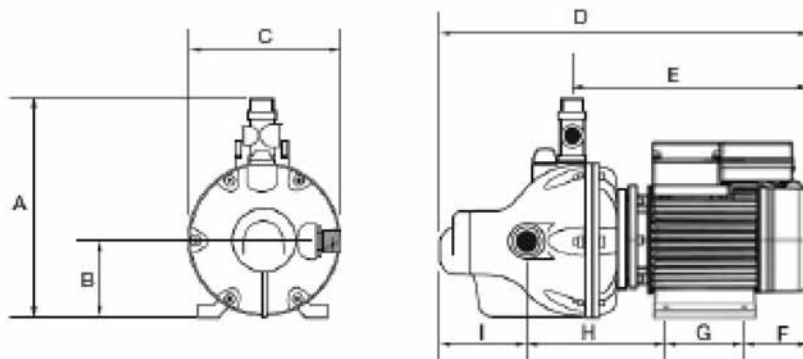

Type	A	B	C	D	E	F	G	H	I
543	290	100	230	530	330	110	100	205	115



1-21 Monash Drive | Dandenong South, VIC 3175 | Australia | 1300 137 344 | onga.com.au

Information contained here-in remains the property of Pentair under Australian copyright law. Content may not be reproduced or transmitted without our prior written permission. Disclaimer: Pentair reserves the right to change product specifications and products details. Product images are for reference purposes only and may not represent the actual/current product.

©2021 Pentair. All rights reserved.